

Orchestrating a brighter world

NEC

Professional projectors of high performance and brighter LCD models that are lightweight and compact
Professional Installation Projector

PA803U / PA723U / PA653U
PA853W / PA703W / PA903X



HDBT™
ASE

HDMI®
HIGH-DEFINITION MULTIMEDIA INTERFACE

D™

A compact projector solution for large venue applications and vertical markets boasts Ultra HD support, wider colour space, scaling, resolution and reduced maintenance

A High-efficiency Design with High-brightness Projection and Reduced Maintenance

The Lightest and Most Compact WUXGA Projector Over 8000 lumens (NP-PA803U)*

A lightweight and compact WUXGA projector (NP-PA803U) of 10.2 kg, 33.23 liters** and 8000 lumens brightness with NEC's unique cooling system for the LCD panel (patented) and the lamp.

* Not including lens, according to our research as of January 2017
** Not including protruding parts

NEC's unique LCD cooling method

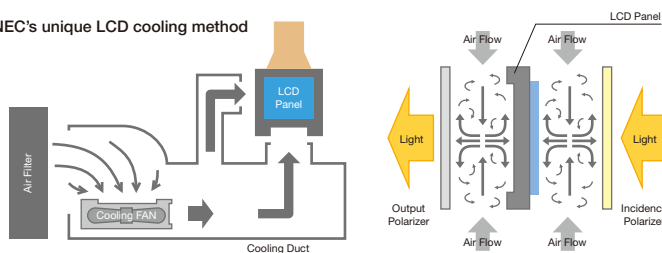

An Energy-saving Design with Standby Power Consumption

When the on-screen menu's standby mode is set to "NORMAL", power consumption in standby mode with power management on is 0.15 W (100 – 130 V) / 0.21 W (200 – 240 V) and 0.11 W (100 – 130 V) / 0.16 W (200 – 240 V) when the LAN is off.

Reduce Maintenance and Expenses

When Eco mode is used, lamp replacement time is extended to a maximum of 5,000 hours*. At the same time, the maximum usage time for the filter is 10,000 hours**. This virtually maintenance-free filter reduces the frequency at which cleaning is required, thereby decreasing total cost of ownership.

* This time is not guaranteed.
** Varies by projector installation conditions.



A High-definition Design to Meet the Era of High-resolution Content and Devices

NEC's Unique High-definition Functionality with the 4th Generation of "SweetVision" for 4K Content

"SweetVision" newly supports 4K 60 Hz input signals and has been upgraded to support HDR10 and Rec.2020 signal inputs. It offers a high definition image by raising the contrast in the boundary parts of an image by using the "Craik-O'Brien-Cornsweet effect".

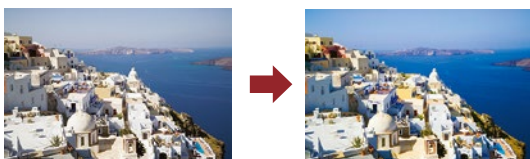

Supports High-definition Processing of Both Digital and Analogue Inputs

10-bit high-definition signal processing is possible with all digital and analogue inputs. An image can be projected with an excellent contrast of 1024 gradations and over 1 billion colours in 4K images.

4K Ready

The New PA series supports HDR10 and BT.2020 signals for various 4K content (including next generation "Ultra HD Blu-ray" and "4K TV broadcasting").

Multiple Input Terminals for HDMI and DisplayPort and Input and Output Terminals for HDBaseT

The First Projector Available Worldwide with Built-in HDBaseT (IN/OUT) Support (NP-PA803U)*

Simplify your installations with HDBaseT. The projector is optimized for video applications and supports uncompressed full HD digital video, audio, Ethernet, power and control signals. With only a single cable (up to 100 m) to run, infrastructure and labour costs are reduced, installations are significantly easier, and there is no cable clutter to manage. With uncompressed HD video support, images have never been more stunning. What's more, control signals are contained in the same cable.

* Passed the examination of the testing agencies approved by the HDBaseT Alliance as of December 15th, 2016. Website of HDBaseT Alliance: <http://hdbaset.org/advanced-search>

A Wide Selection of Digital Inputs such as HDMI and DisplayPort

Among the PA Series' wide selection of inputs are dual HDMI with HDCP and DisplayPort with HDCP for connecting to high-definition sources such as Blu-ray players, cable boxes, satellite receivers and personal computers.

Terminals

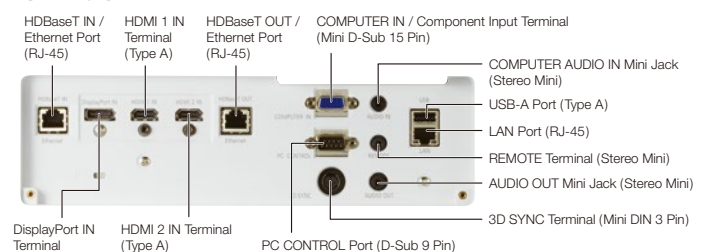

Excellent Ease of Installation and Functionality in Various Uses and Applications

Multi-screen Function

Multi-display capabilities and tiling technologies are integrated. The projector is also equipped with multiple digital input and HDBaseT output terminals that can connect multiple projectors in a digital daisy chain. These cutting-edge functions produce a beautiful high-resolution image, including a 4K high-resolution display using 4 projectors and various picture-in-picture and picture-by-picture configurations.

Screen Splitter

NEC is committed to bringing the latest and greatest Innovations to projectors. Multi-display capabilities and TileMatrix technologies are integrated into these projectors by using the HDBaseT repeater function (IN/OUT). This processing is all done internally and therefore eliminates the additional hardware typically required to produce a beautiful 4K resolution image.

Screen Splitter (Multi-display) by Daisy Chain

Using four WUXGA projectors to project videos with a resolution of 4K (3,840 x 2,160 pixels) [TILING] On-screen menu operations

- 1 Use four projectors to display four similar videos.
- 2 Operate the on-screen menu using the four respective projectors to divide the image into four portions.
- 3 Adjust the lens shift of each projector to fine-tune the boundaries of the screen.

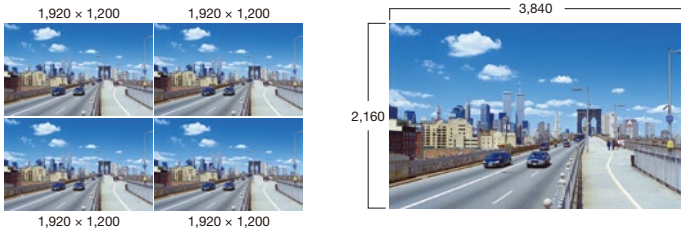

Optional Lens specifications

Model	NP44ML*	NP11FL	NP30ZL	NP12ZL	NP13ZL	NP14ZL	NP40ZL	NP41ZL	NP43ZL
Lens Type	Fixed Ultra Short Throw Lens	Fixed Short Throw Lens	Zoom Lens (Short Throw)	Zoom Lens	Zoom Lens	Zoom Lens	Zoom Lens	Zoom Lens	Zoom Lens
Zoom / Focus	Motorised (Focus)	Manual (Focus)	Manual	Manual	Manual	Manual	Motorised	Motorised	Motorised
F# (Wide - Tele)	2.0	2.3	1.9-2.1	2.2-2.7	1.7-2.4	2.2-2.6	2.0-2.5	1.7-2.0	2.2-2.6
f (mm)	6.27	13.2	13.2-17.2	19.4-25.3	24.4-48.6	48.5-77.6	13.3-18.6	21.8-49.7	49.7-99.8
Throw ratio (WUXGA @ 100 inch)	0.32:1	0.79:1	0.79-1.04:1	1.16-1.52:1	1.46-2.95:1	2.90-4.68:1	0.79-1.11:1	1.30-3.02:1	2.99-5.93:1
Zoom Ratio	—	—	1.3	1.3	2.0	1.6	1.4	2.3	2.0
Screen Size (Performance guarantee range)	80-400 inch (100-350 inch)	40-160 inch** (60-150 inch)	50-500 inch (60-180 inch)	30-500 inch (40-200 inch)	30-500 inch (40-200 inch)	60-500 inch (60-200 inch)	50-500 inch (80-200 inch)	50-500 inch (80-200 inch)	50-500 inch (80-200 inch)
Light Output	NP-PA803U	6,240 lumens	5,400 lumens	7,600 lumens	5,800 lumens	8,000 lumens	6,100 lumens	6,800 lumens	8,000 lumens
	NP-PA723U	5,610 lumens	4,800 lumens	6,800 lumens	5,300 lumens	7,200 lumens	5,500 lumens	6,100 lumens	7,200 lumens
	NP-PA653U	5,070 lumens	4,400 lumens	6,200 lumens	4,800 lumens	6,500 lumens	5,000 lumens	5,500 lumens	6,500 lumens
	NP-PA853W	6,630 lumens	6,000 lumens	8,100 lumens	6,400 lumens	8,500 lumens	6,500 lumens	7,200 lumens	8,500 lumens
	NP-PA703W	5,460 lumens	5,000 lumens	6,700 lumens	5,300 lumens	7,000 lumens	5,400 lumens	5,900 lumens	7,000 lumens
	NP-PA903X	7,020 lumens	6,800 lumens	8,600 lumens	7,100 lumens	9,000 lumens	7,400 lumens	7,600 lumens	9,000 lumens
	NP-PA903X	7,020 lumens	6,800 lumens	8,600 lumens	7,100 lumens	9,000 lumens	7,400 lumens	7,600 lumens	9,000 lumens
Weight	3.1 kg	1.2 kg	1.14 kg	1.2 kg	0.84 kg	1.0 kg	1.6 kg	1.8 kg	1.8 kg

* After installing the lens unit NP44ML on the projector, be sure to secure it to the projector using the support kit (NP01LK) sold separately.
 * The lens unit NP44ML does not support LENS CALIBRATION, LENS SHIFT and LENS MEMORY. ** WUXGA and WXGA models: 40-150 inch

Other Useful Functions and Features

- Cornerstone
- Geometric correction to project an image on more non-standard surfaces
- Stacking correction to boost image brightness
- Centre lens design for easy setup
- Lens memory
- Carbon meter to check the amount of reduction of CO₂ in eco mode
- Seamless switch function for smoother screen changes when switching the signal
- Network control
 - NaViSet Administrator 2
 - PC control
 - Alert mail
 - CRESTRON ROOMVIEW
 - AMX BEACON
 - PJLink
 - HTTP server (projector adjustment)
- Wall colour correction
- PIN security / control panel lock / security bar / security slot
- DICOM simulation

Edge Blending

This function seamlessly blends multiple projected images to display a single high-resolution image.



New Optional Lenses with Peripheral Motorised Focus Features and Advanced Dust-proof Construction

Nine types of optional lenses are available along with the new NP40ZL, NP41ZL and NP43ZL as dust proof lenses with motorised zoom/focus and with a memory function. A selection of wide zoom lenses with wide vertical and horizontal lens shift and control code emulation are available, guaranteeing hassle-free installation and replacement of existing projectors. The new ultra short throw lens of NP44ML can eliminate space challenges with shorter projection distances. (100" at only 0.7 m distance) The NP40ZL, NP41ZL and NP44ML are also equipped with peripheral motorised focus, and focus adjustment is possible in two stages by the centre and the periphery, which offers excellent image quality.

* After installing the NP44ML on the projector, be sure to secure it to the projector using the support kit (NP01LK) sold separately.

Tilt-free and Portrait Installation Support

The projector can be rotated freely (360°) to point up or down depending on the installation requirements and can be rotated and installed on its side to create a portrait image.

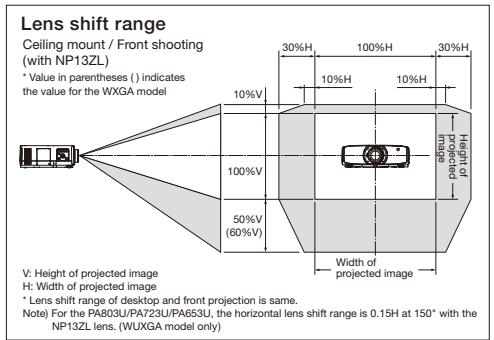
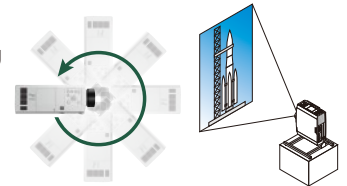

PA803U
 8,000 lumens WUXGA 10.2kg

PA723U
 7,200 lumens WUXGA 10.2kg

PA653U
 6,500 lumens WUXGA 10.2kg

PA853W
 8,500 lumens WXGA 10.2kg

PA703W
 7,000 lumens WXGA 10.2kg

PA903X
 9,000 lumens XGA 10.2kg

Brightness of each model using with NP13ZL or NP41ZL. Weight of each model does not include lens.

